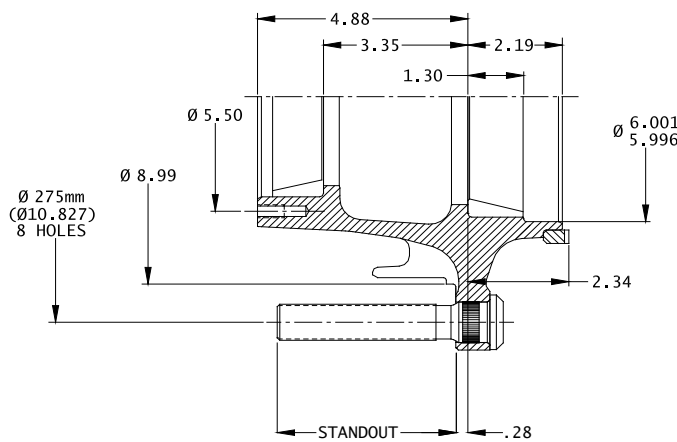
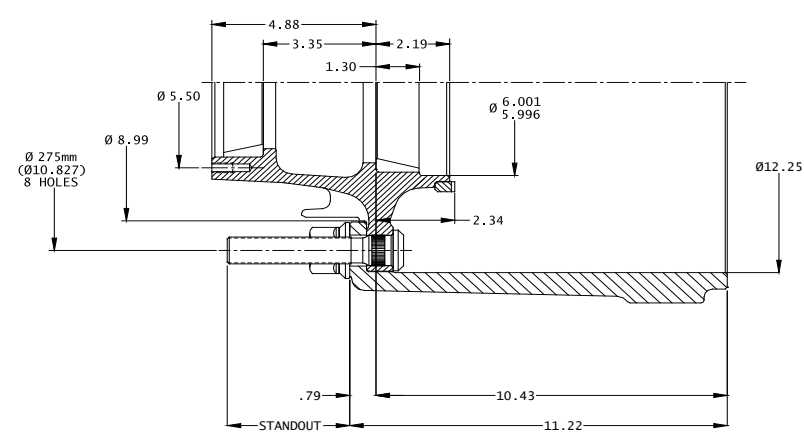

Walther Engineering and Manufacturing Co., Inc.

Part Number	Application	Standout	Lbs.	Bolts	Part Number	Application	Standout	Lbs.	Bolts																		
Low-Boy Hubs for N Tapered-Spindle Axles					Low-Boy Hubs for N Tapered-Spindle Axles with 12 1/4 x 7.5" Cast Drum																						
10-00048-001	Hub HP, AL Whl	4.14"	40	02-00045	10-00048-031*	Hub/Cast Drum Assy. HP, AL Whl	3.64"	133	02-00045																		
10-00048-002	Hub HP, ST Whl	3.21"	39	02-00044	10-00048-032*	Hub/Cast Drum Assy. HP, ST Whl	2.71"	132	02-00044																		
10-00048-101	ABS Hub HP, AL Whl	4.14"	41	02-00045	10-00048-131*	ABS Hub/Cast Drum Assy. HP, AL Whl	3.64"	134	02-00045																		
10-00048-102	ABS Hub HP, ST Whl	3.21"	40	02-00044	10-00048-132*	ABS Hub/Cast Drum Assy. HP, ST Whl	2.71"	133	02-00044																		
																											
					NOTE: BRAKE SIZE 12.25" X 7.50"																						
Hub Dynamic Load Ratings					Component Parts																						
<table border="1"> <thead> <tr> <th>Wheel Offset</th> <th>Load/Hub</th> </tr> </thead> <tbody> <tr> <td>0</td> <td>10,000 lbs</td> </tr> <tr> <td>0.56"</td> <td>N/A</td> </tr> <tr> <td>2.00"</td> <td>N/A</td> </tr> <tr> <td>2.38"</td> <td>N/A</td> </tr> <tr> <td>2.75"</td> <td>N/A</td> </tr> <tr> <td>3.50"</td> <td>N/A</td> </tr> <tr> <td>3.88"</td> <td>N/A</td> </tr> <tr> <td>6.66"</td> <td>N/A</td> </tr> </tbody> </table>		Wheel Offset	Load/Hub	0	10,000 lbs	0.56"	N/A	2.00"	N/A	2.38"	N/A	2.75"	N/A	3.50"	N/A	3.88"	N/A	6.66"	N/A	<table border="1"> <tbody> <tr> <td>03-00050</td> <td>12 1/4" x 7.5" Cast Brake Drum</td> <td>93 lbs</td> </tr> <tr> <td>02-39702</td> <td>Metform - Two-piece, Flanged Wheel Nut, M22x1.5</td> <td>.4 lbs</td> </tr> </tbody> </table>		03-00050	12 1/4" x 7.5" Cast Brake Drum	93 lbs	02-39702	Metform - Two-piece, Flanged Wheel Nut, M22x1.5	.4 lbs
Wheel Offset	Load/Hub																										
0	10,000 lbs																										
0.56"	N/A																										
2.00"	N/A																										
2.38"	N/A																										
2.75"	N/A																										
3.50"	N/A																										
3.88"	N/A																										
6.66"	N/A																										
03-00050	12 1/4" x 7.5" Cast Brake Drum	93 lbs																									
02-39702	Metform - Two-piece, Flanged Wheel Nut, M22x1.5	.4 lbs																									
Lubricant Fill Volumes 15 fl-oz Oil Lubrication Fill Level 61.40 in³ Vol. Between Cup Seats Including Spindle Displacement 17.01 fl-oz 50% Fill Level for Semi-Fluid, Including Spindle Displacement					N Bearings HM212011 bearing cup - outer bore HM218210 bearing cup - inner bore HM212049 bearing cone - outer bore HM218248 bearing cone - inner bore																						